



**INSTITUTO DE CIENCIAS
DE LA CONSTRUCCIÓN
EDUARDO TORROJA**

C/ Serrano Galvache n. 4 28033 Madrid (Spain)
Tel.: (34) 91 302 04 40 Fax: (34) 91 302 07 00
direccion.ietcc@csic.es www.ietcc.csic.es

European Technical Assessment

ETA 17/0073 of 25/04/2017

English translation prepared by IETcc. Original version in Spanish language

General Part

Technical Assessment Body issuing the ETA designated according to Art. 29 of Regulation (EU) 305/2011

Instituto de Ciencias de la Construcción Eduardo Torroja (IETcc)

Trade name of the construction product

SPIT FIX Z XTREM.220

Product family to which the construction product belongs

Torque controlled expansion anchor made of galvanized steel of sizes M12 and M16 for use in concrete.

Manufacturer

SPIT
Route de Lyon 150
26500 Bourg Lés Valence, France.
website: www.spit.com

Manufacturing plants

Plant 2

This European Technical Assessment contains

13 pages including 3 annexes which form an integral part of this assessment.

This European Technical Assessment is issued in accordance with regulation (EU) No 305/2011, on the basis of

European Technical Assessment EAD 330232-00-0601 "Mechanical Fasteners for use in concrete", ed. October 2016

English translation prepared by IETcc

This European Technical Assessment is issued by the Technical Assessment Body in its official language. Translations of this European Technical Assessment in other languages shall fully correspond to the original issued document and should be identified as such.

This European Technical Assessment may be withdrawn by the issuing Technical Assessment Body, in particular pursuant to information by the Commission according to article 25 (3) of Regulation (EU) No 305/2011.

SPECIFIC PART

1. Technical description of the product

The SPIT FIX Z XTREM.220 wedge anchor in the range of M12 and M16 is an anchor made of galvanised steel. The anchor is installed into a predrilled cylindrical hole and anchored by torque-controlled expansion. The anchorage is characterised by friction between expansion clip and concrete.

Product and product description is given in annex A.

2. Specification of the intended use in accordance with the applicable European Assessment Document.

The performances given in section 3 are only valid if the anchor is used in compliance with the specifications and conditions given in annex B.

The verifications and assessment methods on which this European Technical Assessment is based lead to the assumption of a working life of the anchor of at least 50 years. The indications given on the working life cannot be interpreted as a guarantee given by the producer, but are to be regarded only as a mean to choosing the right products in relation to the expected economically reasonable working life of the works.

3. Performance of the product and references to the methods used for its assessment

3.1 Mechanical resistance and stability (BWR 1)

Essential characteristic	Performance
Characteristic resistance under static or quasi static loading	See annexes C1 to C3
Displacements under tension and shear loads	See annex C3
Characteristic resistance under seismic loading categories C1 and C2	See annex C4 and C5

3.2 Safety in case of fire (BWR 2)

Essential characteristic	Performance
Reaction to fire	Anchorage satisfy requirements for class A1
Resistance to fire	See annex C6

3.3 Hygiene, health and the environment (BWR 3)

This requirement is not relevant for the anchors.

3.4 Safety in use (BWR 4)

The essential characteristics regarding safety in use are included under the basic works requirements Mechanical resistance and stability.

English translation prepared by IETcc

3.5 Protection against noise (BWR 5)

This requirement is not relevant for the anchors.

3.6 Energy economy and heat retention (BWR 6)

This requirement is not relevant for the anchors.

3.7 Sustainable use of natural resources (BWR 7)

No performance determined

4. Assessment and verification of constancy of performance (hereinafter AVCP) system applied, with reference to its legal base

The applicable European legal act for the system of Assessment and Verification of Constancy of Performances (see annex V to Regulation (EU) No 305/2011) is 96/582/EC.

The system to be applied is 1.

5. Technical details necessary for the implementation of the AVCP system, as provided for in the applicable European Assessment Document.

The technical details necessary for the implementation of the AVCP system are laid down in the quality plan deposited at Instituto de ciencias de la construcción Eduardo Torroja.



Instituto de ciencias de la construcción Eduardo Torroja
CONSEJO SUPERIOR DE INVESTIGACIONES CIENTÍFICAS

C/ Serrano Galvache n.º 4. 28033 Madrid.
Tel: (+34) 91 302 04 40 Fax. (+34) 91 302 07 00
www.ietcc.csic.es



On behalf of the Instituto de Ciencias de la Construcción Eduardo Torroja
Madrid, 25th of April 2017

Marta M^a Castellote Armero
Director

English translation prepared by IETcc

Product and installed condition

SPIT FIX Z XTREM 220 anchor

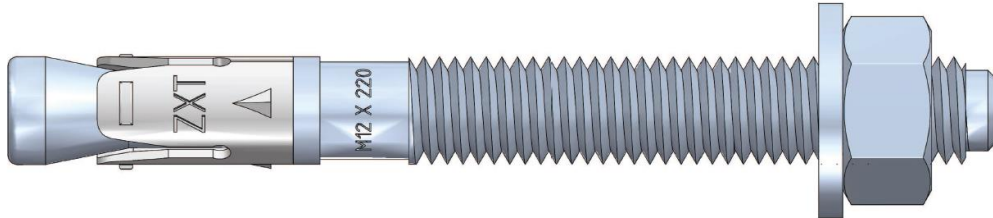

Identification on anchor:

- Expansion clip:
 - Anchor SPIT FIX Z XTREM 220: Company logo + "FIX" + "ZXT".
- Anchor body: Metric x Length
- Length letter code on head:.....O

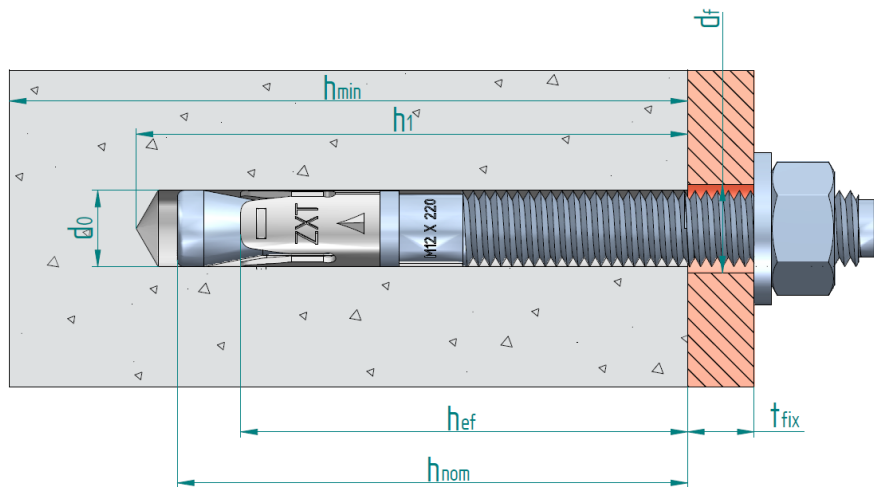

- d_0 : Nominal diameter of drill bit
- d_f : Fixture clearance hole diameter
- h_{ef} : Effective anchorage depth
- h_1 : Depth of drilled hole
- h_{nom} : Overall anchor embedment depth in the concrete
- h_{min} : Minimum thickness of concrete member
- t_{fix} : Fixture thickness

SPIT FIX Z XTREM.220 anchor	Annex A1
Product description	
Installed condition	

English translation prepared by IETcc

Table A1: materials

Item	Designation	Material for SPIT FIX Z XTREM.220 anchor
1	Anchor body	Carbon steel wire rod, galvanized $\geq 5 \mu\text{m}$ ISO 4042 A2
2	Washer	DIN 125, DIN 9021 galvanized $\geq 5 \mu\text{m}$ ISO 4042 A2
3	Nut	DIN 934 galvanized $\geq 5 \mu\text{m}$ ISO 4042 A2, class 6
4	Expansion clip	Stainless steel, grade A4

SPIT FIX Z XTREM.220 anchor

Product description

Materials

Annex A2

English translation prepared by IETcc

Intended use

Anchorage subjected to:

- Static or quasi static loads.
- Seismic actions:
 - for performance category C1: SPIT FIX Z XTREM.220 M12 and M16
 - for performance category C2: SPIT FIX Z XTREM.220 M12 and M16
- Fire exposure.

Base materials:

- Reinforced or unreinforced normal weight concrete according to EN 206-1.
- Strength classes C20/25 to C50/60 according to EN 206-1.
- Cracked or uncracked concrete.

Use conditions (environmental conditions):

- The anchor shall only be used in dry internal conditions.

Design:

- Anchorages are designed under the responsibility of an engineer experienced in anchorages and concrete.
- Verifiable calculation rules and drawings are prepared taking into account of the loads to be attached. The position of the anchor is indicated on the design drawings (e.g. position of the anchor relative to reinforcement or to supports, etc.).
- Anchorages under static or quasi-static actions are designed for design method A in accordance with:
 - ETAG 001, Annex C, edition August 2010 or
 - CEN/TS 1992-4:2009.
 - prEN1992-4
- Anchorages under seismic actions (cracked concrete) are designed in accordance with:
 - EOTA Technical Report TR 045, edition February 2013
 - prEN1992-4
 - Anchorages shall be positioned outside of critical regions (e.g. plastic hinges) of the concrete structure
 - Fastening in stand-off installation or with grout layer are not allowed.
- Anchorages under fire exposure are designed in accordance with:
 - ETAG 001, Annex C, design method A, edition August 2010 and EOTA Technical Report 020, edition May 2004
 - CEN/TS 1992-4-1:2009, annex D.
 - prEN 1992-4
 - It must be ensured that local spalling of the concrete cover does not occur.

Installation:

- Hammer drilling only.
- Anchor installation carried out by appropriately qualified personal and under the supervision of the person responsible for technical matters of the site.
- In case of aborted hole: new drilling at a minimum distance away of twice the depth of aborted hole or smaller distance if the aborted hole is filled with high strength mortar and if under shear or oblique tension load it is not the direction of the load application.

SPIT FIX Z XTREM.220 anchor		Annex B1
Intended use		
Specifications		

English translation prepared by IETcc

Table C1: Installation parameters for SPIT FIX Z XTREM.220 anchor

Installation parameters			Performances	
			M12 x 220	M16 x 220
d_o	Nominal diameter of drill bit:	[mm]	12	16
d_f	Fixture clearance hole diameter:	[mm]	14	18
T_{inst}	Nominal installation torque:	[Nm]	60	100
L	Total length of the bolt:	[mm]	220	220
h_{min}	Minimum thickness of concrete member:	[mm]	140	170
h_1	Depth of drilled hole:	[mm]	85	105
h_{nom}	Overall anchor embedment depth in the concrete:	[mm]	80	97
h_{ef}	Effective anchorage depth:	[mm]	70	85
t_{fix}	Thickness of fixture:	[mm]	124	103
s_{min}	Minimum allowable spacing:	[mm]	70	85
c_{min}	Minimum allowable distance:	[mm]	70	85

Installation process

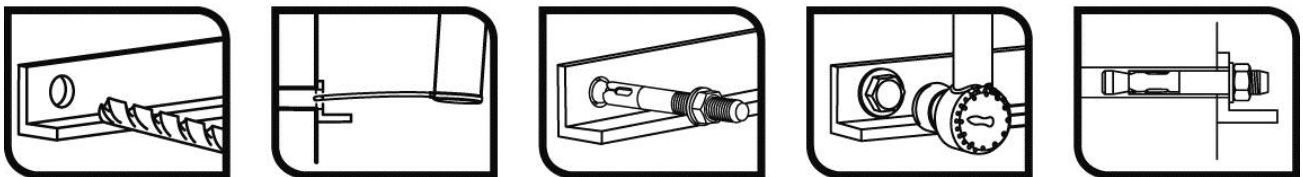

SPIT FIX Z XTREM.220 anchor

Performances

Installation parameters and installation procedure

Annex C1

English translation prepared by IETcc

Table C2: Characteristic values to tension loads of design method A according to ETAG 001, Annex C or CEN/TS 1992-4 for SPIT FIX Z XTREM.220 anchor

Characteristic values of resistance to tension loads of design according to design method A		Performance			
		M12 x 220	M16 x 220		
Tension loads: steel failure					
$N_{Rk,s}$	Characteristic resistance:	[kN]	40.4	72.7	
γ_{Ms}	Partial safety factor:	[-]	1.5	1.5	
Tension loads: pull-out failure in concrete					
$N_{Rk,p,ucr}$	Characteristic resistance in C20/25 uncracked concrete:	[kN]	20	35	
$N_{Rk,p,cr}$	Characteristic resistance in C20/25 cracked concrete:	[kN]	12	25	
$\gamma_{ins}^{2)}$ $\gamma_{ins}^{1)}$	Installation safety factor:	[-]	1.0	1.0	
Ψ_c	Increasing factor for $N_{Rk,p}^0$	C30/37	[-]	1.22	1.22
		C40/50	[-]	1.41	1.41
		C50/60	[-]	1.55	1.55
Tension loads: concrete cone and splitting failure					
h_{ef}	Effective embedment depth:	[mm]	70	85	
$k_{ucr,N}$	Factor for uncracked concrete:	[-]	10.1		
$k_{cr,N}$	Factor for cracked concrete:	[-]	7,2		
$\gamma_{ins}^{2)}$ $\gamma_{ins}^{1)}$	Installation safety factor:	[-]	1.0	1.0	
$S_{cr,N}$	Concrete cone failure:	[mm]	3 x h_{ef}		
$C_{cr,N}$		[mm]	1.5 x h_{ef}		
$S_{cr,sp}$	Splitting failure:	[mm]	350	425	
$C_{cr,sp}$		[mm]	175	213	

¹⁾ Parameter relevant only for design according to CEN/TS 1992-4:2009

²⁾ Parameter relevant only for design according to ETAG 001, Annex C

SPIT FIX Z XTREM.220 anchor	Annex C2
Performances	
Characteristic values for tension loads	

English translation prepared by IETcc

Table C3: Characteristic values to shear loads of design method A according to ETAG 001, Annex C or CEN/TS 1992- for SPIT FIX Z XTREM.220 anchor

Characteristic values of resistance to shear loads of design according to design method A			Performance	
			M12 x 220	M16 x 220
Shear loads: steel failure without lever arm				
$V_{Rk,s}$	Characteristic resistance:	[kN]	25.3	47.1
$k_2^{1)}$	k_2 factor:	[-]	1.0	
γ_{Ms}	Partial safety factor:	[-]	1.25	1.25
Shear loads: steel failure with lever arm				
$M_{Rk,s}^0$	Characteristic bending moment:	[Nm]	78.6	199.8
γ_{Ms}	Partial safety factor:	[-]	1.25	1.25
Shear loads: concrete pryout failure				
$k_3^{2)}$ $k_3^{1)}$	k factor:	[-]	2	2
$\gamma_{2-1}^{2)}$ $\gamma_{ins}^{1)}$	Installation safety factor:	[-]	1.0	
Shear loads: concrete edge failure				
l_f	Effective length of anchor under shear loads:	[mm]	70	85
d_{nom}	Outside anchor diameter:	[mm]	12	16
$\gamma_{2-1}^{2)}$ $\gamma_{ins}^{1)}$	Installation safety factor:	[-]	1.0	

¹⁾ Parameter relevant only for design according to CEN/TS 1992-4:2009

²⁾ Parameter relevant only for design according to ETAG 001, Annex C

Table C4: Displacements under tension load for SPIT FIX Z XTREM.220 anchor

Displacements under tension loads			Performance	
			M12	M16
SPIT FIX Z XTREM.220				
N	Service tension load:	[kN]	6.3	10.4
\bar{D}_{N0}	Short term displacement:	[mm]	1.0	0.4
$\bar{D}_{N\infty}$	Long term displacement:	[mm]	1.9	1.9

Table C5: Displacements under shear load for SPIT FIX Z XTREM.220 anchor

Displacements under shear loads			Performance	
			M12	M16
SPIT FIX Z XTREM.220				
V	Service shear load:	[kN]	8.5	15.1
\bar{D}_{V0}	Short term displacement:	[mm]	1.8	1.9
$\bar{D}_{V\infty}$	Long term displacement:	[mm]	2.7	2.9

SPIT FIX Z XTREM.220 anchor

Performances

Displacements under tension and shear loads

Annex C3

English translation prepared by IETcc

Table C6: Design information for seismic performance C1 SPIT FIX Z XTREM.220 anchor

Design information for seismic performance C1			Performance	
			M12 x 220	M16 x 220
Steel failure for tension and shear failure				
$N_{Rk,s,seis}$	Characteristic tension steel failure:	[kN]	40.4	72.7
$\gamma_{Ms,N}$	Partial safety factor:	[-]	1.5	1.5
$V_{Rk,p,seis}$	Characteristic shear steel failure:	[kN]	17.8	33.0
$\gamma_{Ms,V}$	Partial safety factor:	[-]	1.25	1.25
Pull out failure				
$N_{Rk,p,seis}$	Characteristic pull out failure:	[kN]	8.4	17.5
$\gamma_{ins}^{2)}$ $\gamma_{ins}^{1)}$	Installation safety factor:	[-]	1.0	1.0
Concrete cone failure				
h_{ef}	Effective embedment depth:	[mm]	70	85
$s_{cr,N}$	Spacing:	[mm]	3 x h_{ef}	
$c_{cr,N}$	Edge distance:	[mm]	1.5 x h_{ef}	
$\gamma_{ins}^{2)}$ $\gamma_{ins}^{1)}$	Installation safety factor:	[-]	1.0	1.0
Concrete pryout failure				
$k^{2)}$ $k_3^{1)}$	k factor:	[-]	2	2
Concrete edge failure				
l_f	Effective length of anchor:	[kN]	70	85
d_{nom}	Outside anchor diameter:	[-]	12	16

¹⁾ Parameter relevant only for design according to CEN/TS 1992-4:2009

²⁾ Parameter relevant only for design according to ETAG 001, Annex C

SPIT FIX Z XTREM.220 anchor

Performances

Design information for seismic performance C1

Annex C4

English translation prepared by IETcc

Table C7: Design information for seismic performance C2 SPIT FIX Z XTREM.220 anchor

Design information for seismic performance C2			Performance	
			M12 x 220	M16 x 220
Steel failure for tension and shear failure				
$N_{Rk,s,seis}$	Characteristic tension steel failure:	[kN]	40.4	72.7
$\gamma_{Ms,N}$	Partial safety factor:	[-]	1.5	1.5
$V_{Rk,p,seis}$	Characteristic shear steel failure:	[kN]	17.8	33.0
$\gamma_{Ms,V}$	Partial safety factor:	[-]	1.25	1.25
Pull out failure				
$N_{Rk,p,seis}$	Characteristic pull out failure:	[kN]	5.2	8.9
$\gamma_{ins}^{2)}$ $\gamma_{ins}^{1)}$	Installation safety factor:	[-]	1.0	1.0
Concrete cone failure				
h_{ef}	Effective embedment depth:	[mm]	70	85
$s_{cr,N}$	Spacing:	[mm]	3 x h_{ef}	
$c_{cr,N}$	Edge distance:	[mm]	1.5 x h_{ef}	
$\gamma_{ins}^{2)}$ $\gamma_{ins}^{1)}$	Installation safety factor:	[-]	1.0	1.0
Concrete pryout failure				
$k^{2)}$ $k_3^{1)}$	k factor:	[-]	2	2
Concrete edge failure				
l_f	Effective length of anchor:	[kN]	70	85
d_{nom}	Outside anchor diameter:	[-]	12	16
Displacements				
$\bar{O}_{N,seis} (DSL)$	Displacement Damage Limitation State: ^{3) 4)}	[mm]	2.34	3.99
$\bar{O}_{V,seis} (DSL)$		[mm]	5.53	5.96
$\bar{O}_{N,seis} (USL)$	Displacement Ultimate Limit State: ³⁾	[mm]	9.54	10.17
$\bar{O}_{V,seis} (USL)$		[mm]	9.08	10.66

¹⁾ Parameter relevant only for design according to CEN/TS 1992-4:2009

²⁾ Parameter relevant only for design according to ETAG 001, Annex C

³⁾ The listed displacements represent mean values

⁴⁾ A small displacement may be required in the design in the case of displacements sensitive fastening of "rigid" supports. The characteristics resistance associated with such small displacements may be determined by linear interpolation or proportional reduction.

SPIT FIX Z XTREM.220 anchor

Performances

Design information for seismic performance C2

Annex C5

English translation prepared by IETcc

Table C8: Characteristic values for resistance to fire SPIT FIX Z XTREM.220 anchor

Anchor SPIT FIX Z XTREM.220		M12 x 220	M16 x 220	
Steel failure				
$N_{Rk,s,fi}$	Characteristic tension resistance	R30 [kN]	1,7	3,1
		R60 [kN]	1,3	2,4
		R90 [kN]	1,1	2,0
		R120 [kN]	0,8	1,6
$V_{Rk,s,fi}$	Characteristic shear resistance	R30 [kN]	1,7	3,1
		R60 [kN]	1,3	2,4
		R90 [kN]	1,1	2,0
		R120 [kN]	0,8	1,6
$M^0_{Rk,s,fi}$	Characteristic bending resistance	R30 [kN]	2,6	6,7
		R60 [kN]	2,0	5,0
		R90 [kN]	1,7	4,3
		R120 [kN]	1,3	3,3
Pull out failure				
$N_{Rk,p,fi}$	Characteristic resistance	R30 [kN]	3,0	6,3
		R60 [kN]		
		R90 [kN]	2,4	5,0
		R120 [kN]		
Concrete cone failure⁴⁾				
$N_{Rk,p,fi}$	Characteristic resistance	R30 [kN]	7,4	12,0
		R60 [kN]		
		R90 [kN]	5,9	9,6
		R120 [kN]		
$S_{cr,N,fi}$	R30 to R120 [mm]	4 x h_{ef}		
$C_{cr,N,fi}$	R30 to R120 [mm]	2 x h_{ef}		
In case of fire attack from more than one side the minimum edge distance shall be ≥ 300 mm and $2 \times h_{ef}$				
Concrete pry out failure				
$k^2_{1)3}$	R30 to R120 [-]	2	2	

¹⁾ Parameter relevant only for design according to CEN/TS 1992-4:2009

²⁾ Parameter relevant only for design according to ETAG 001, Annex C

⁴⁾ As a rule, splitting failure can be neglected since cracked concrete and reinforcement is assumed.

SPIT FIX Z XTREM.220 anchor

Performances

Characteristic values for resistance to fire

Annex C6