

PSN100

500705

Strip Nailer

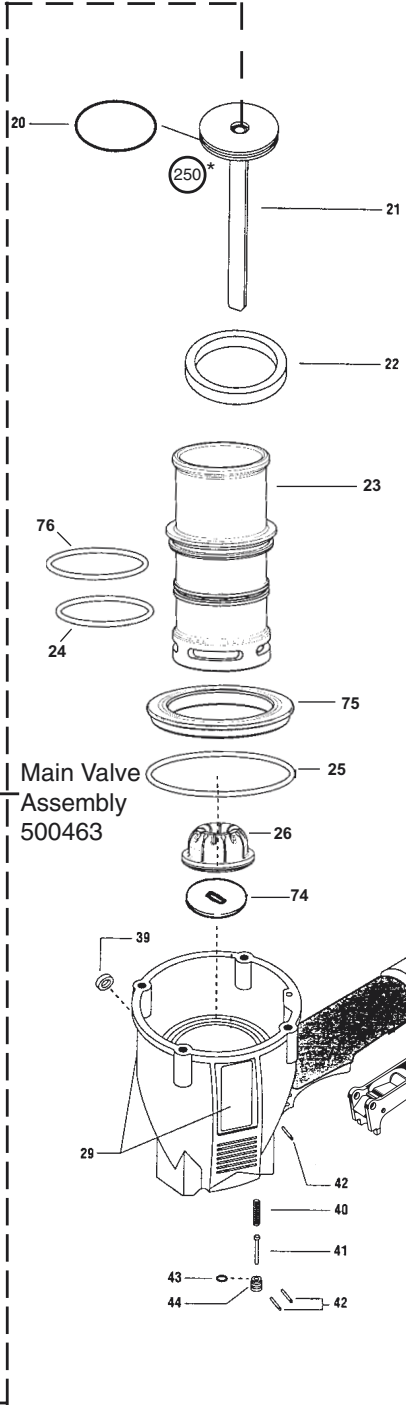
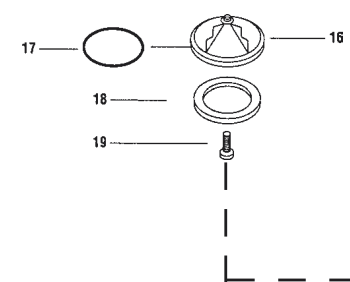
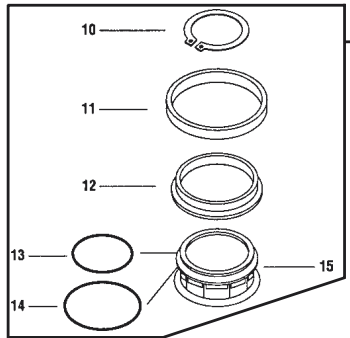
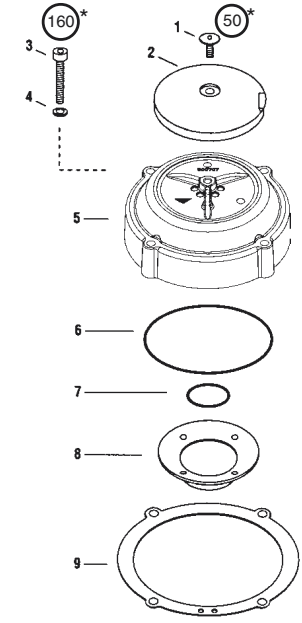

Main Valve Assembly
500463

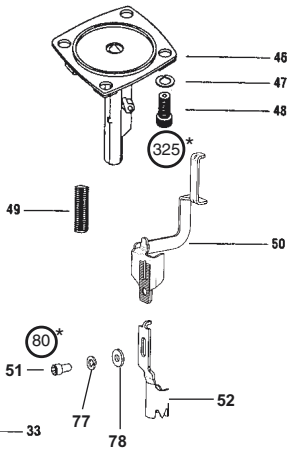
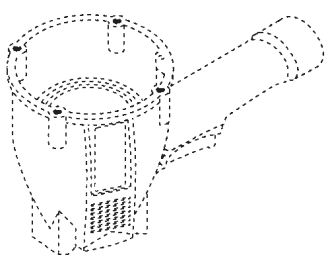

Trigger Assembly
501048

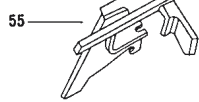
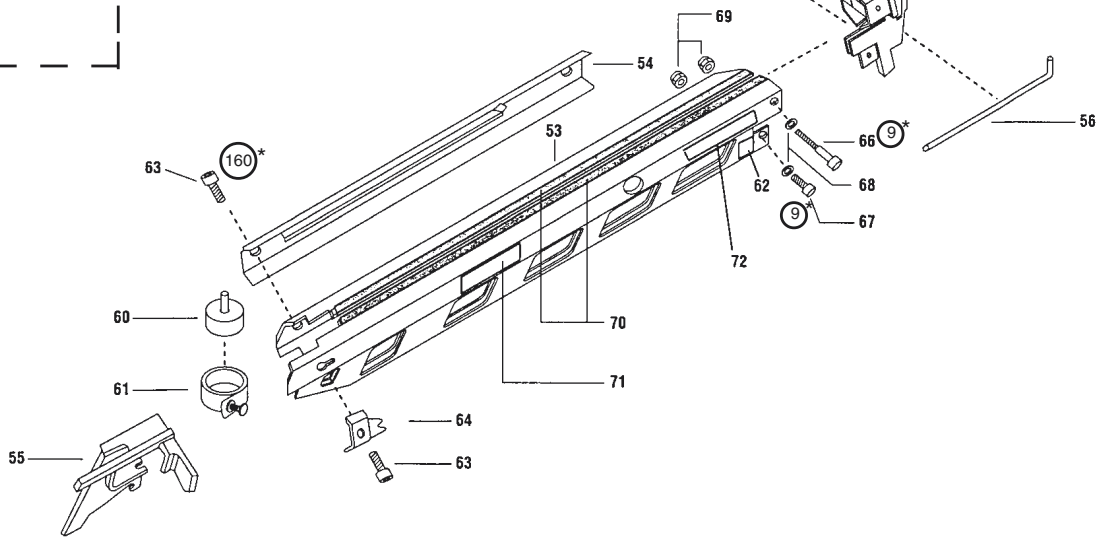

Ref. No.	Part No.	Qty	Description
1	501043	1	T.H.S.C.S. 1/4 -20 x 1/2"
2	501016	1	Air Deflector
3	091873	4	S.H.C.S. 1/4-20 x 2"
4	092757	4	Flatwasher 1/4"
5	500707	1	Cap
6	500461	1	O-Ring
7	092042	2	O-Ring
8	500407	1	Spring, Main Valve
9	501001	1	Gasket, Cap
10	406041	1	Retaining Ring
11	500455	1	Upper Valve Piston
12	401946	1	Seal, Main Valve
13	091208	1	O-Ring
14	401950	1	O-Ring
15	500456	1	Lower Valve Piston
16	500454	1	Post
17	095432	1	O-Ring
18	500453	1	Bumper, Post
19	402906	1	B.H.S.C.S.10-32 x 5/8"
20	092971	1	O-Ring, Piston
21	500709	1	Piston Assembly
22	402011	1	Seal Sleeve
23	500710	1	Sleeve
24	092235	1	O-Ring, Sleeve
25	501002	1	O-Ring
26	500866	1	Bumper
27	501286	1	Housing
29	501333	1	Label, Housing-Leftside
	501334	1	Label, Housing-Rightside
30	501219	1	End Cap, Housing
31	500516	1	B.H.S.C.S. - Special
32	404274	1	Flatwasher
33	500525	1	Locknut, 5/16-24
34	091622	1	Reducing Pipe Bushing
35	501010	1	Trigger
36	402669	1	Pin, Trigger
37	501009	1	Spirol Pin
38	501008	1	Lever, Bottom Trip
39	402668	1	Retaining Ring
40	097748	1	Spring, Valve Pin
41	097746	1	Valve Pin
42	071297	3	Roll Pin 1/8 x 1-1/8"
43	092174	1	O-Ring, Valve Body
44	401958	1	Valve Body
46	500712	1	Nose 30°
47	095417	4	Lockwasher 5/16

Ref. No.	Part No.	Qty	Description
48	009016	4	S.H.C.S. 5/16-18 x 1"
49	501006	1	Spring, W.C.E.
50	501363	1	Upper W.C.E.
51	091618	1	S.H.C.S. 1/4-20 x 1/2"
52	500713	1	Lower W.C.E.
53	501491	1	Magazine with Wear Strips
54	500717	1	Nail Cover
55	500531	1	Follower
56	501044	1	3/16 Hex Key, Long Arm
57	501024	1	End Cap, Magazine-LF
58	501025	1	End Cap, Magazine-RT
59	501027	1	Latch
60	501046	1	Drum Pin Assembly
61	500513	1	Negator Assembly
62	500839	1	Nameplate
63	404904	2	Screw 1/4-28 x 5/8"
64	500509	1	Front Bracket
65	501028	1	Spring, Latch
66	501026	1	S.H.C.S. 8-32 x 2"
67	066840	1	S.H.C.S. 8-32 x 3/4"
68	404414	2	Flatwasher #8
69	404325	2	Stop Nut
70	500520	2	Wear Strip
71	500458	1	Warning Label
72	500838	2	Logo Label
74	500729	1	Blade Seal
75	500779	1	Flange, Sleeve
76	500249	1	O-Ring, Sleeve
77	002187	1	Lock Washer
78	404800	1	Flat Washer
79	501039	1	Sequential Trigger
80	501299	2	S.H.C.S. 1/4-20 x 1"